

NX410 PRO



NX410 PRO with options

NX410 PRO Technical Data

Weight	640 kg
Voltage	230 V Mono / 230 V - 3 phase
	400 V - 3 phase
Dust suction outlet	100 mm
	+ 60 mm on sawguard

Versions

250 mm sawblade	with scoring unit (100 x 20 mm)
315 mm sawblade	without scoring unit

Saw

Saw rotation speed	4500 RPM
Diameter saw blade and bore	250 x 30 mm / 315 x 30 mm
Cutting depth at 90°	85 mm / 107 mm
Cutting depth at 45°	55 mm / 70 mm
Dimensions cast iron table	1080 x 410 mm
Dimensions sliding table	1450 mm (option 2050 mm) x 320 mm
Cutting length	1600 mm (option 2000/2500 mm)
Cutting width parallel fence	900 mm
Motor power 3 phase (S6)	4,85 kW / 6,6 hp
Motor power single phase (S6)	2,2 kW / 3 hp

Spindle

Spindle rotation speed	3000 / 6000 / 7500 / 10000 RPM
Diameter spindle arbor	30 mm (option 50 mm)
Capacity spindle arbor	122 mm
Travel	140 mm
Dimensions table opening	180 mm
Motor power 3 phase (S6)	4,85 kW / 6,6 hp
Motor power single phase (S6)	2,2 kW / 3 hp

Planer-Thickener

Total length planer tables	1800 mm
Height capacity thickener	230 mm
Diameter cutter block	70 mm
Knives	3
Dimensions knives	410 x 25 x 3 mm
Planer thickener width	410 mm
Max. depth of cut	4 mm
Feeding speed	6 m/min
Cutter block rotation speed	5500
Motor power 3 phase (S6)	4,85 kW / 6,6 hp
Motor power single phase (S6)	2,2 kW / 3 hp

Mortiser (option)

Chuck	0 - 16 mm
Travel	165 x 140 x 85 mm

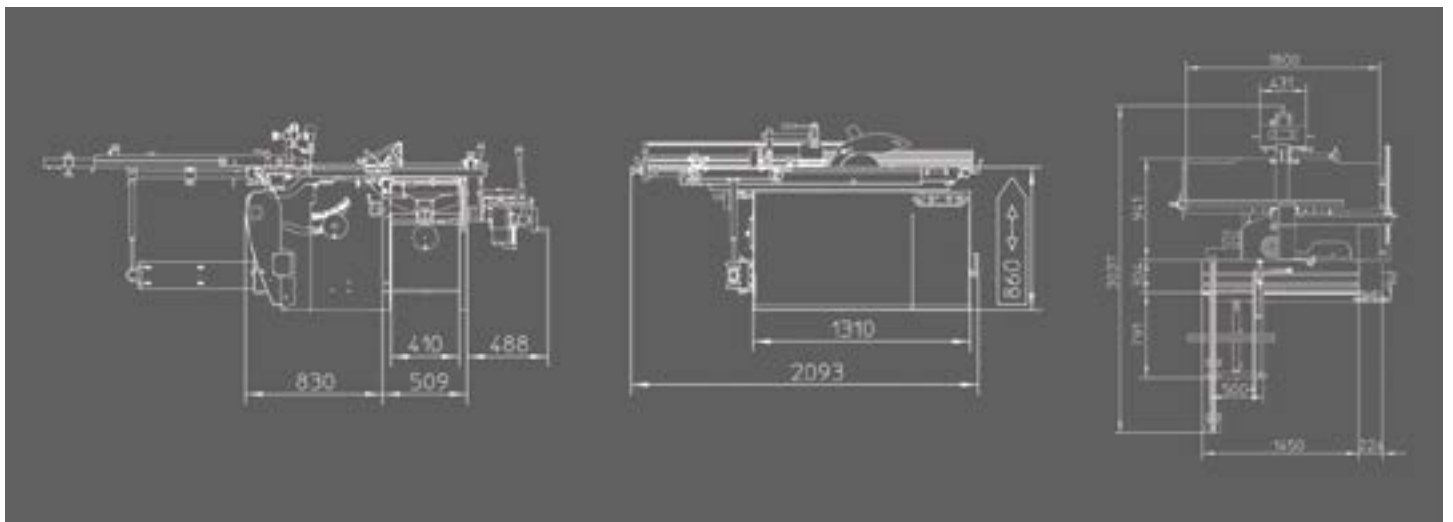

COMBINED MACHINES

OVERVIEW

COMBINED 4 – 6 operations

	HX260	HX310 PRO	NX310 PRO (315)
Optional tenoner and mortiser	O	O	O
Machine in monophase	O	O	O
Outrigger table	-	S	S
Mitre fence with excentric clamp	S	S	S

Motors

Number of motors	3	3	3
Motor power (S6, 40% duty cycle) for 3 phase	3 kW	3 kW	3,7 kW
Motor power (S6, 40% duty cycle) for single phase	2,2 kW	2,2 kW	2,2 kW

Saw

Scoring unit	-	-	-
Diameter main saw (mm)	250	250	315
Max cutting depth 90° (mm)	85	85	107
Max cutting length standard (mm)	1200	1450	1600
Max cutting length optional (mm)	-	2100	2500
Max cutting width standard with paralel fence (mm)	600	655	800
Parallel fence on round bar	-	-	-
Digital read out on flippers and parallel fence	-	-	-

Spindle Moulder

Diameter standard (mm)	30	30	30
Diameter optional (mm)	-	50	1 1/4" / 32 /50
Speed (1000 rpm)	3/6	3/6	3/4/6/7,5
Fold away power feeder support table	O	O	S
Heavy duty topcap on linear guidings	-	-	-
Ring guard fence	O	O	O

Planer thicknesser

Width of cutterblock (mm)	260	310	310
Cutterblock with resharppable blades	S	S	S
Tersa cutter block	-	O	O
Spiral cutter block	-	O	O

	HXTZ	NXTZ(315)
Optional tenoner	O	O
Optional mortiser	-	-
Machine in monophase	O	O
Outrigger table	-	S
Mitre fence with excentric clamp	S	S

Motors

Number of motors	2	2
Motor power (S6, 40% duty cycle)	3 kW	3,7 kW

Saw

Scoring unit	-	-
Diameter main saw (mm)	250	315
Max cutting depth 90° (mm)	85	107
Max cutting length standard (mm)	1200	1600
Max cutting length optional (mm)	2100	2500
Max cutting width standard with paralel fence (mm)	600	900
Max cutting width optional with paralel fence (mm)	-	1250
Parallel fence on round bar	-	S
Digital read out on flippers and parallel fence	-	-

Spindle Moulder

Diameter standard (mm)	30	30
Diameter optional (mm)	-	1 1/4" / 32 /50
Speed (1000 rpm)	3/6	3/4/6/7,5
Fold away power feeder support table	O	S
Heavy duty topcap on linear guidings	-	-
Ring guard fence	O	O

Planer thicknesser

Width of cutterblock (mm)	-	-
Cutterblock with resharppable blades	-	-
Tersa cutter block	-	-
Spiral cutter block	-	-

S = Present / O = Optional / - = Not available

NX310 PRO (250)	NX410 PRO (315)	NX410 PRO (250)	NLX310 PRO	NLX410 PRO
O	O	O	O	O
O	O	O	-	-
S	S	S	S	S
S	S	S	S	S
3	3	3	3 + 1	3 + 1
3,7 kW	4,4 kW	4,4 kW	4,4 kW + 0,6 kW	4,4 kW + 0,6 kW
2,2 kW	2,2 kW	2,2 kW	2,2 kW + 0,6 kW	2,2 kW + 0,6 kW
S	-	S	S	S
250	315	250	300	300
85	107	85	100	100
1600	1600	1600	2500	2500
2500	2500	2500	3100	3100
800	800	800	800	900
-	-	-	S	S
-	-	-	O	O
30	30	30	30	30
1 1/4" / 32 /50	1 1/4" / 32 /50	1 1/4" / 32 /50	1 1/4" / 32 /50	1 1/4" / 32 /50
3/4/6/7,5	3/4/6/7,5	3/4/6/7,5	3/4/6/7,5	3/4/6/7,5
S	S	S	S	S
-	-	-	O	O
O	O	O	O	O
310	410	410	310	410
S	S	S	S	S
O	O	O	O	O
O	O	O	O	O
NXTZ(250)	NLXTZ	XSD310	NXSD310	NXSD 410
O	O	-	-	-
-	-	O	O	O
O	-	O	O	O
S	S	-	-	-
S	S	-	-	-
2	2 + 1	1	1	4,4kW
3,7 kW	4,4 kW + 0,6 kW	3,4 kW	3,7 kW	
S	S	-	-	-
250	300	-	-	-
85	100	-	-	-
1600	2500	-	-	-
2500	3100	-	-	-
900	900	-	-	-
1250	1250	-	-	-
S	S	-	-	-
-	O	-	-	-
30	30	-	-	-
1 1/4" / 32 /50	1 1/4" / 32 /50	-	-	-
3/4/6/7,5	3/4/6/7,5	-	-	-
S	S	-	-	-
-	O	-	-	-
O	O	-	-	-
-	-	310	310	410
-	-	S	S	S
-	-	O	O	O
-	-	O	O	O



This brochure is for information purposes only. Robland reserves the right to modify machine configurations and specifications without prior notice. Standard configurations can change over time and by point of purchase. Please consult your local dealer for accurate and up to date information.

Robland NV
Kolvestraat 44
8000 Brugge - Belgium
Tel: +32 50 458 925
info@robland.com
www.robland.com



Follow us on Facebook
www.facebook.com/Roblandmachines



Follow us on Instagram
www.instagram.com/robland_nv



Follow us on YouTube
www.youtube.com/robland